



University of Michigan
Taubman College for Architecture
and Urban Planning

2000 Bonisteel Boulevard
Ann Arbor, MI 48109

SUMMER 2013

Afterhouse

Summer 2013, University of Michigan

Steven Mankouche, Ph.D.

Abigail Murray

Edward Sach

Matthew Schulte

Jono Sturt

Travis Williams

Like too many Detroit houses irreparably damaged by disuse, vandalism, and fire; the house at 3347 Burnside must come down. With committed support from the University of Michigan's Taubman College, rather than razing it and leaving fallow land, a group of students, artists, architects, and urban farmers will deconstruct the house and reuse the foundation to build a semi subterranean passive geothermal greenhouse. Afterhouse will be a model and prototype to developing an economically viable kit that can be used with other abandoned house foundations throughout Detroit.

AFTERHOUSE

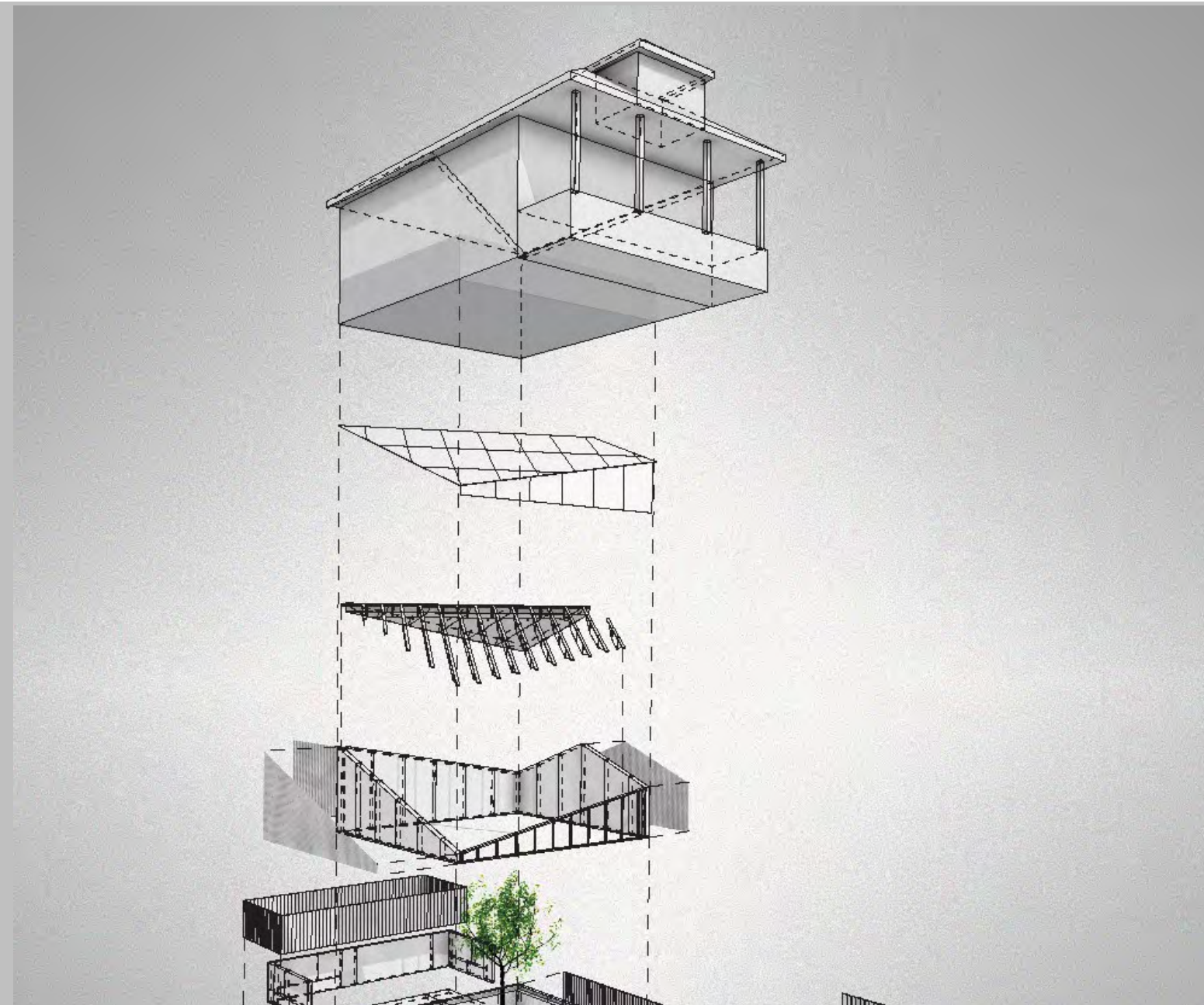

This project is supported in part pursuant to the receipt of financial assistance to the MSU Center for Community and Economic Development from the Michigan State Housing Development Authority (MSHDA). The statements, findings, conclusions, and recommendations are solely those of the authors and do not necessarily reflect the views of any federal, state agency or Michigan State University.



MICHIGAN STATE
UNIVERSITY

University Outreach
and Engagement
Center for Community and Economic Development

Afterhouse



*"I have good memories of
this house, and I have
faith that something good
will happen here again"*

"It's amazing what the fire
did to the inside of this
house. All of the walls are
pitch black.

It's depressing and
beautiful at the same time"

Overview



Like too many Detroit houses irreparably damaged by disuse, vandalism and fire, the house at 3347 Burnside must come down. Rather than razing it and leaving fallow land, the house will be deconstructed and the foundation reused to build a semi subterranean, passive geothermal greenhouse called Afterhouse . Using just the heat of the sun and the constant temperature of the earth, Afterhouse requires no artificial heating in the winter or cooling in the summer and provides an environment where it is possible to raise crops that grow in climates far warmer than Detroit's.

The footprint of the house will be maintained, and vernacular materials used, so that Afterhouse blends into the residential neighborhood and honors stories of the home's history. Distinct from large scale urban agriculture projects that require a lot of

space, Afterhouse is discrete, almost hidden, making it appropriate for denser urban settings where conventional hoop houses and greenhouses are not. The community garden, Burnside Farms, will use and maintain the greenhouse as a place of growth and

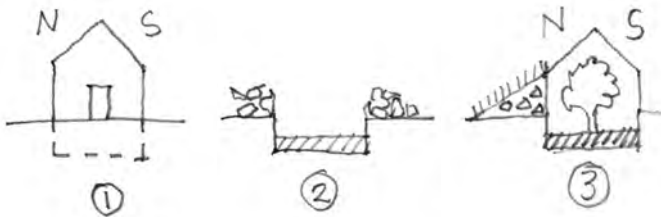

gathering, of warmth and life, during the long cold winter. A derelict house transformed from a hazard to a thing of beauty and of use, drawing from what once was to become a part of what Detroit is now, Afterhouse can serve as a model or prototype for other abandoned houses throughout the surrounding neighborhood.





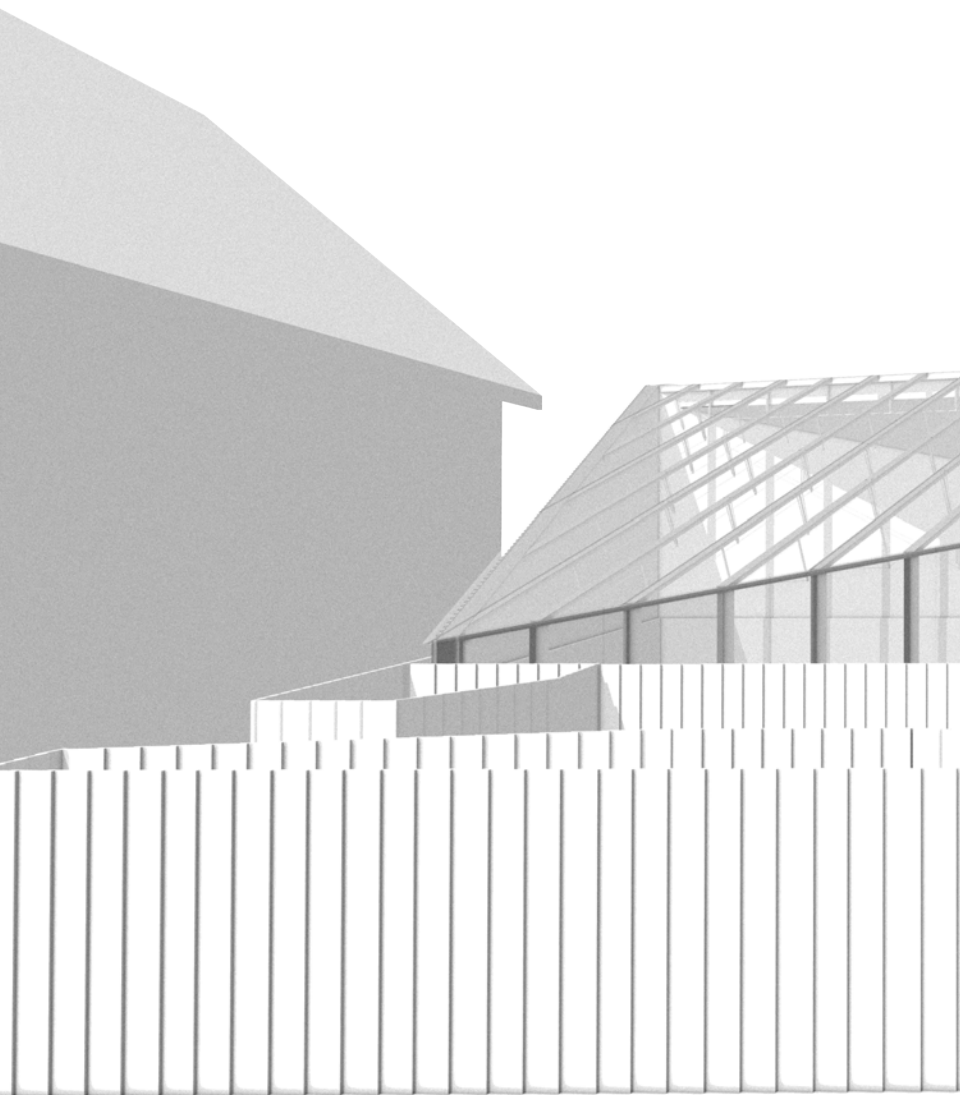

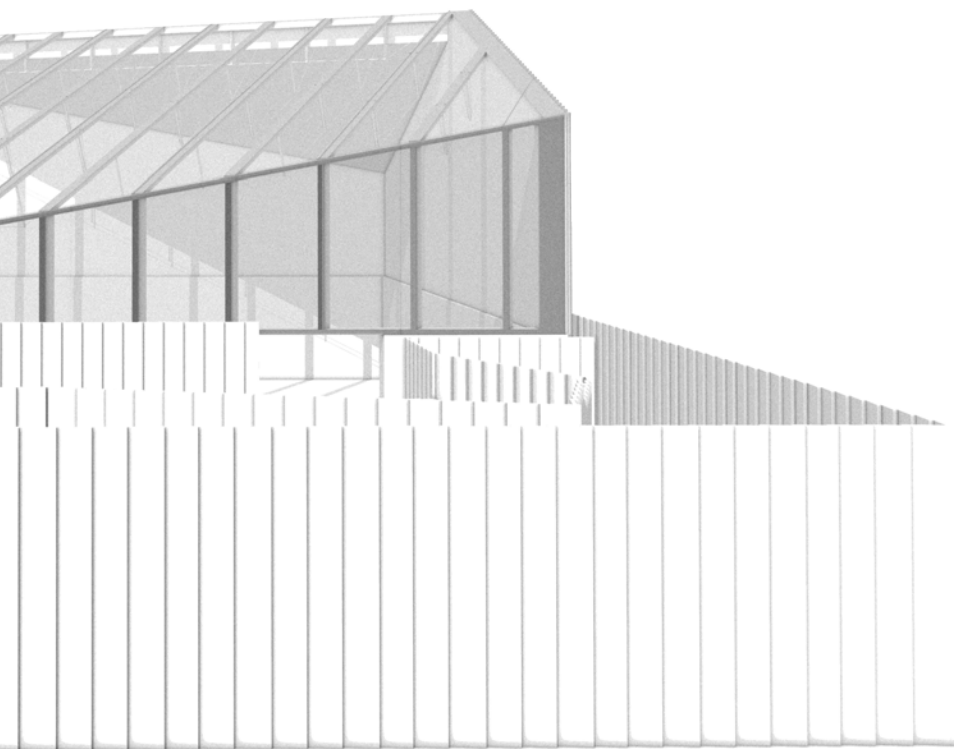

The Story



3347 Burnside's history is not unique. Demographic shifts, economic booms and busts all contribute to its story and the story of many parts Detroit. A typical Blue Collar Bungalow built in the 1920's, it is a part of the first wave of the procedural construction industry as we know it today. Inexpensive, "cookie cutter" houses were built across large neighborhoods for the city's rapidly growing auto worker force, utilizing the same cost savings available through standardization that the auto industry did.

The small, cheap to maintain and heat homes are still attractive to people looking for affordable housing. However, the inexpensive materials and cheap construction present a barrier to restoring the derelict and damaged houses throughout the neighborhood. Rather than see this solely as a problem, Afterhouse takes advantage of this as an opportunity for an

alternative intervention to demolition that contributes to the community and can even be replicated.

WALKING TOUR OF
3347 BURNSIDE
 DETROIT, MICHIGAN, USA



"I broke up a fight in front of this house once."

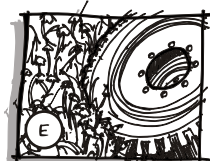

"see that tire? It's been there for forty years."

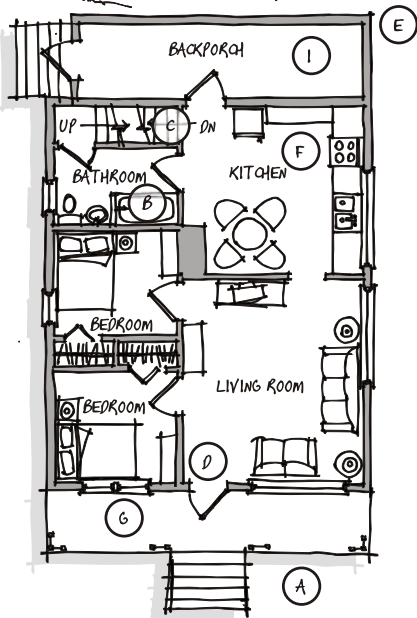

"I remember a family with five little girls lived in that house. Their father would ask to borrow money every time I saw him."

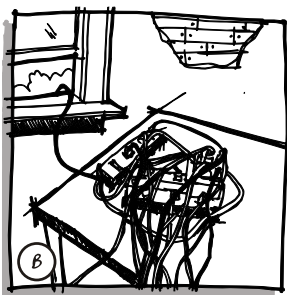

"We used to run an extension cord to the house next door for electricity. The only running water was in the bathtub. We washed dishes, washed clothes and drank water from the tub. Can you imagine?!?"



"This schizophrenic guy lived here with his mama. Sometimes he'd just go off on you. He would mess with people's cars and yell from the front porch. I felt sorry for his mama."

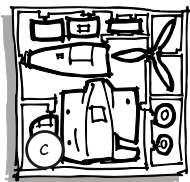

"My Brother and I used to build model airplanes in the basement. We also had a hammock down there!"



"I remember the first time I jumped from our roof to the house next door. I felt like Superman!"

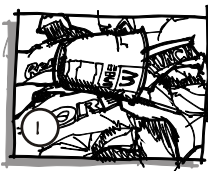

"وكان هذا النادي لدينا"

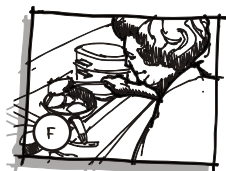

"To była moja babcia w kuchni. Miała piękny ogród w podwórku."

"It's amazing what the fire did to the inside of this house. All of the walls are pitch black. It's depressing and beautiful at the same time"



"I have good memories of this house, and I have faith that something good will happen here again"



1922

Detroit's booming auto industry brought masses of immigrants who used their factory earnings to build or to buy one of the small homes that sprung up almost overnight on the city's open land.

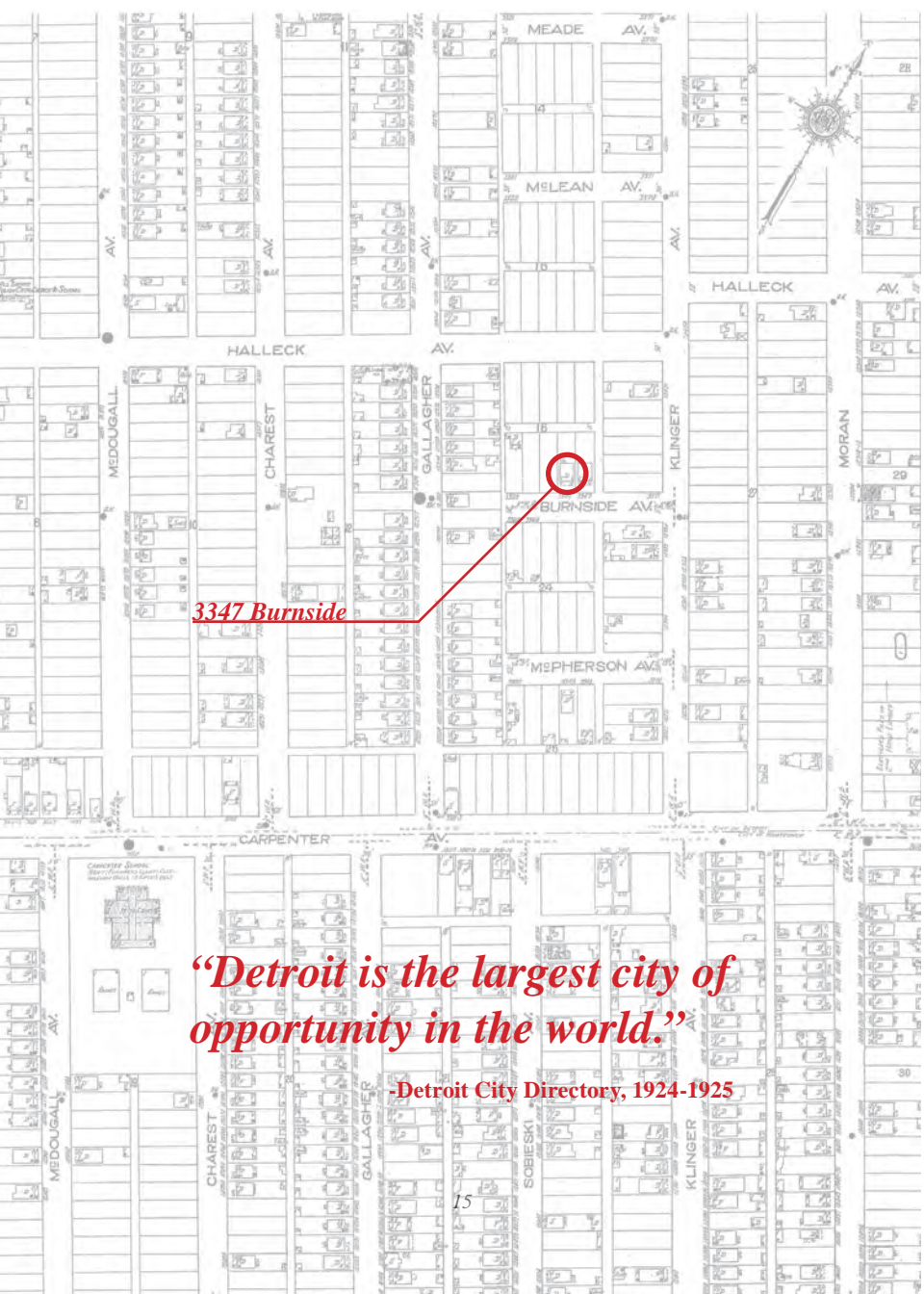

3347 Burnside

“Detroit is the largest city of opportunity in the world.”

-Detroit City Directory, 1924-1925



MODERN HOME No. 401

\$483.00

For \$483.00 we will furnish all the material to build this Five-Room Bungalow, consisting of Mill Work, Lumber, Lath, Shingles, Ceiling, Siding, Flooring, Finishing Lumber, Building Paper, Pipe, Gutter, Sash Weights, Hardware and Painting Material. **NO EXTRAS**, as we guarantee enough material at the above price to build this house according to our plans.

By allowing a fair price for labor, brick, cement and plaster, which we do not furnish, this house can be built for about \$650.00, including all material and labor.

For Our Offer of Free Plans See Page 3.



A BUNGALOW of tasty design. All material is of guaranteed quality. A porch extends across the entire front. The front door is of tempered oak, 1 1/2 inches thick, glazed with hand blown design glass. The parlor and dining room are each 11 feet 2 inches by 12 feet 3 inches and are divided by a large casual opening. Each bedroom has a wardrobe. All interior doors are of the five-panel design, made of the best quality yellow pine, with yellow pine trim to match. All doors are of choice yellow pine.

Built on a concrete block foundation; frame construction. Sided with narrow lapped clear spruce siding. Cedar shingles furnished for the roof. Detailed ten coats of the best paint outside, varnished and wood fiber for two coats of interior finish; a foot 3 inches from door to ceiling.

This house can be built on a lot 30 feet wide.

Quickly built, using inexpensive materials, Blue Collar Bungalow became a popular neighborhood style. Advertisements such as this could be found in catalogues throughout the 1920s.

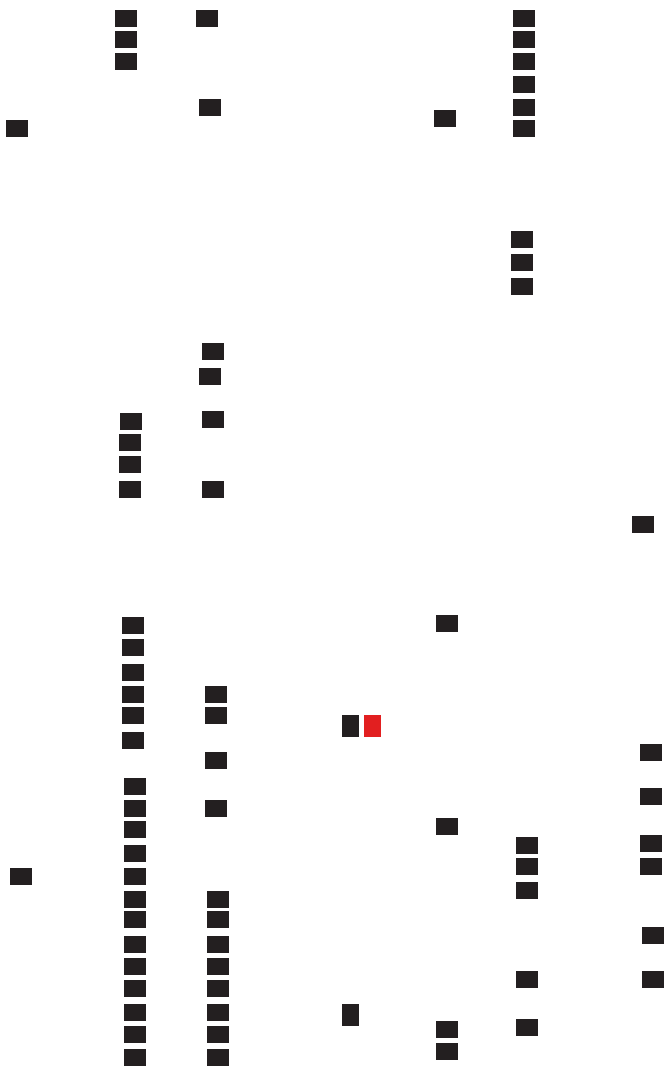

1922 Bungalow Density



1955

After World War II, union-negotiated wage and benefit packages made auto work more secure. At the same time, New Deal programs gave white workers and veterans access to federally-backed mortgages and loan guarantees that made the American Dream more accessible. Homeownership rates skyrocketed and the neighborhood filled in.

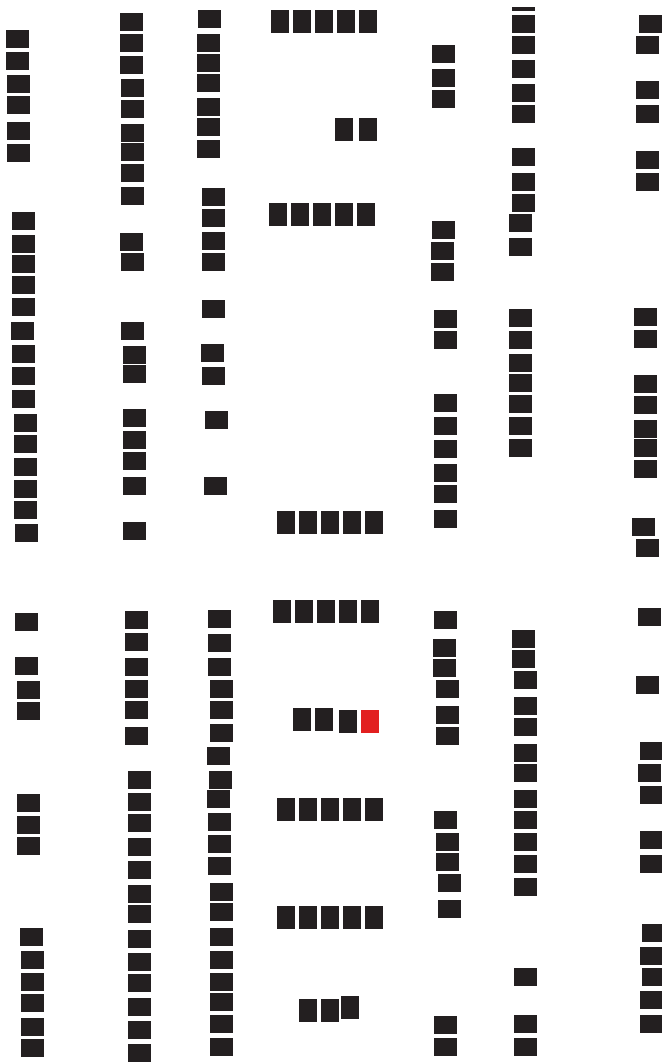

1955 Bungalow Density



2013

Even as much of the city suffered a drastic drop in population, thousands of Bangladeshi immigrants moved to this part of Detroit- so many that the area has been dubbed Banglatown. This influx of people helped the neighborhood maintain its vibrancy and some of its density and made it an attractive place for artists and others to settle despite, or maybe because of the fact that the cheaply built housing stock does not lend itself to gentrification.

The damaged houses that dot the neighborhood are not salvageable, but the embodied energy of the house foundations could be a resource transformed into an asset for the community. Afterhouse is a where food and community will be grown, shared, and celebrated.

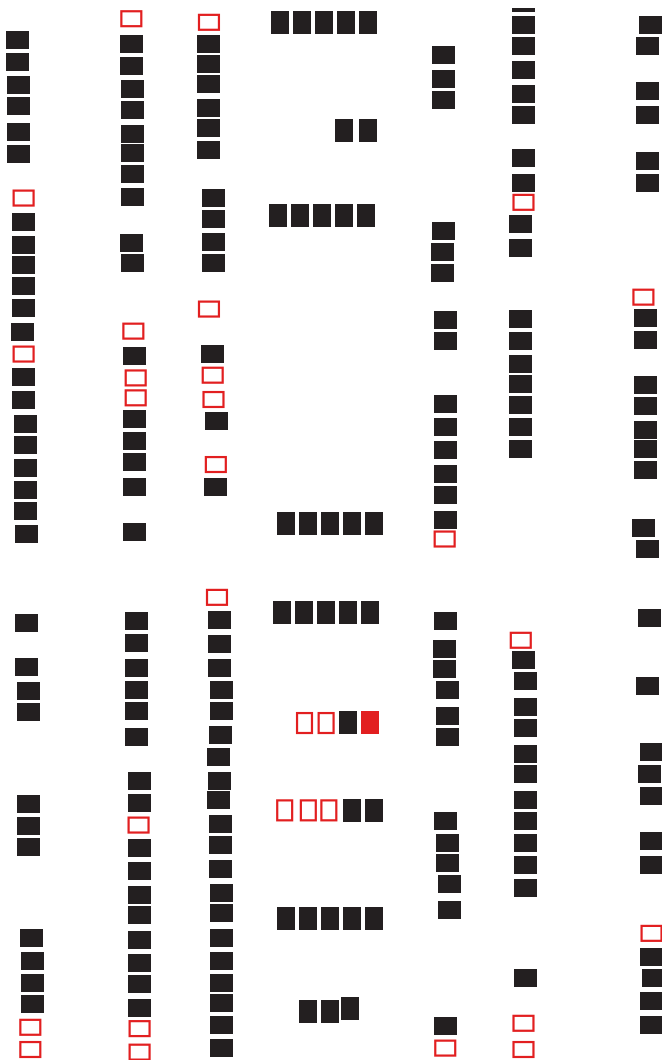

2013 Bungalow Density
(outlined = potential sites of intervention)

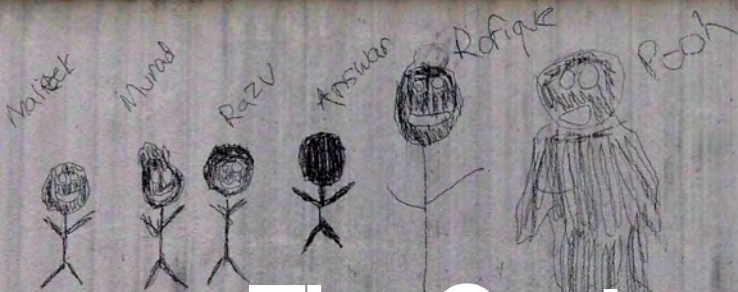

The Cast

The community that surrounds the site for Afterhouse is the determining factor in its success. Here are a few of the individuals who contribute to the project and neighborhood.





The Owner

Artist and committed Detroiter that lived and worked in a house down the street. Concerned about safety, he bought the abandoned, fire damaged house at 3347 Burnside so that he was empowered to discourage vandalism and squatting. As he used his own home as an alternative exhibition space, he hoped that the 3347 house could also be used as a place of artistic or architectural intervention. He collected stories of people who lived there, or remembered people who did and he made drawings that told their stories, and those stories and memories informed the design of Afterhouse.



The Farmer

A Farmer and Artist bought the house next to 3347 Burnside a few years ago as a place to live and work. She subsequently started the urban agriculture project Burnside Farm in the 6 empty lots at the end of the block. The farm and her home are a part of her creative practice and she describes the whole place is a giant studio of sorts. She and her collaborators developed a creative CSA that not only distributes fresh local produce to its shareholders, but curated art objects as well. She will use and maintain Afterhouse as a part of the Burnside Farm, greatly extending her growing season and crop diversity.



The Neighbors

Aside from the owner and the custodian, Afterhouse will serve as a place of warmth for the community in which it resides, transforming the problem of a dangerous structure into a source of engagement and nourishment. The neighborhood surrounding this intervention is diverse and changing. Here are three examples of members of the community:

Long Term Members

Until very recently, the neighborhood was populated mostly by people of Polish origin and their descendants. As job opportunities moved away, so did many of these citizens, but some life long residents remain, and enrich the neighborhood.



New Members

Over the last 30 years, thousands of Bangladeshi immigrants have moved into the neighborhood. This phenomenon has increased the neighborhood's ethnic, cultural and culinary diversity and kept it relatively stable, even as many long term residents moved out.



A New Future

There are many children living in the neighborhood; you can hear them playing in the street after school and on summer days. The blight of the damaged homes presents a particular hazard for them. Afterhouse will increase safety for the neighborhood and stability for the block.





Design

Afterhouse is an alternative to demolition. The typical 1600 square-foot residence has nearly 70 tons of concrete in its foundation that is landfilled in a typical demolition. In addition to losing the embodied energy of the concrete, the foundation removal is energy and labor intensive. Reusing a house's foundation represents a double or triple savings at no additional cost or energy.



(This can be avoided)

1.

The existing building is beyond repair and must be removed, leaving the foundation.

2.

An insulated platform at the street side maintains the cultural and urbanistic disposition of the neighborhood while guarding against temperature fluctuations.

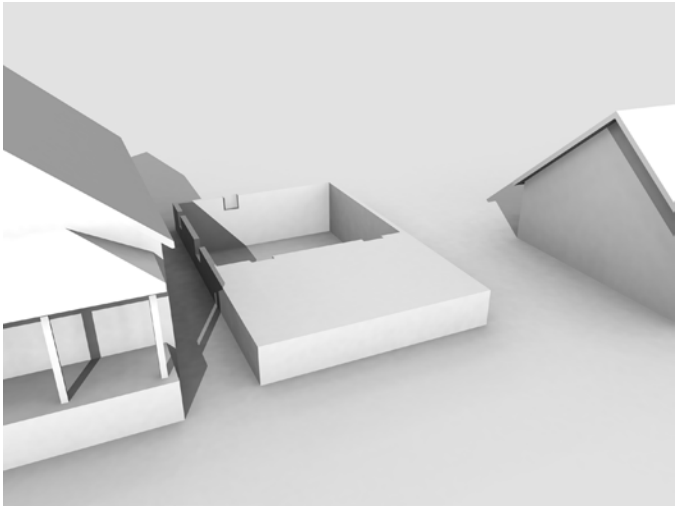
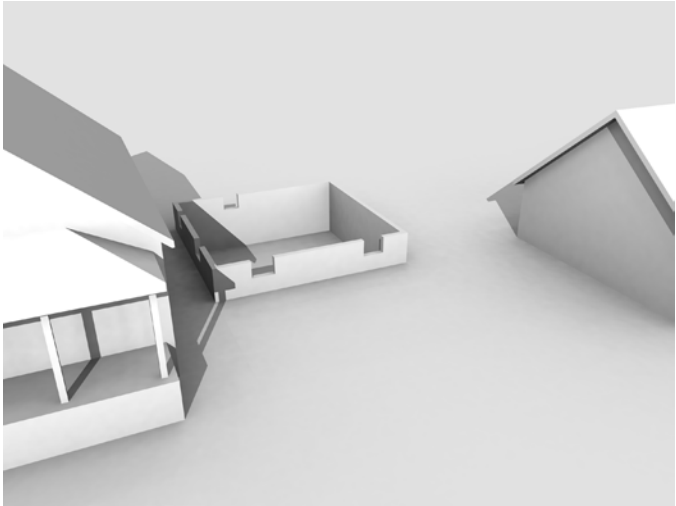

3.

A simple shed-style greenhouse covers the
basement.

4.

The greenhouse is rotated to the South to maximize
solar exposure.

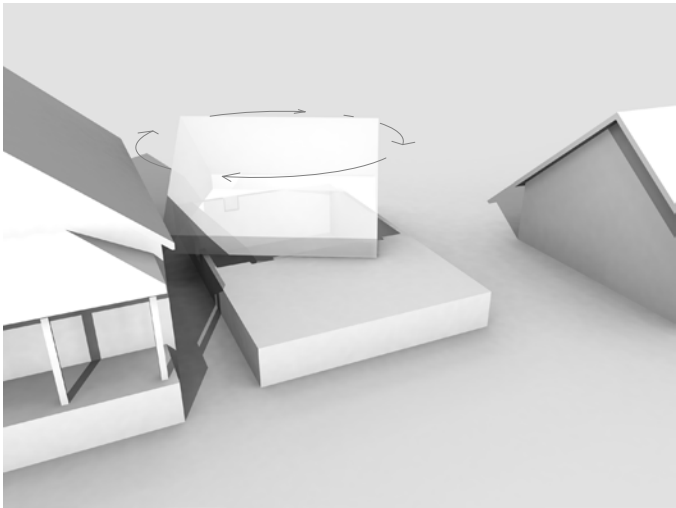
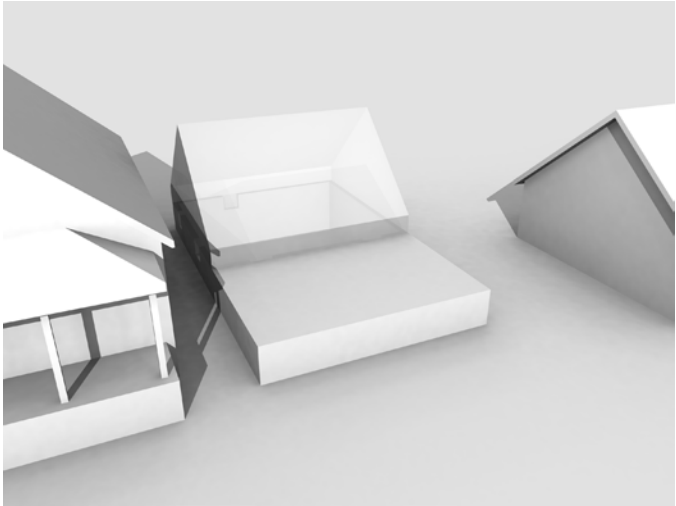

5.

The form is sliced to fit the bounds of the
foundation.

6.

The form is adjusted to meet the foundation.

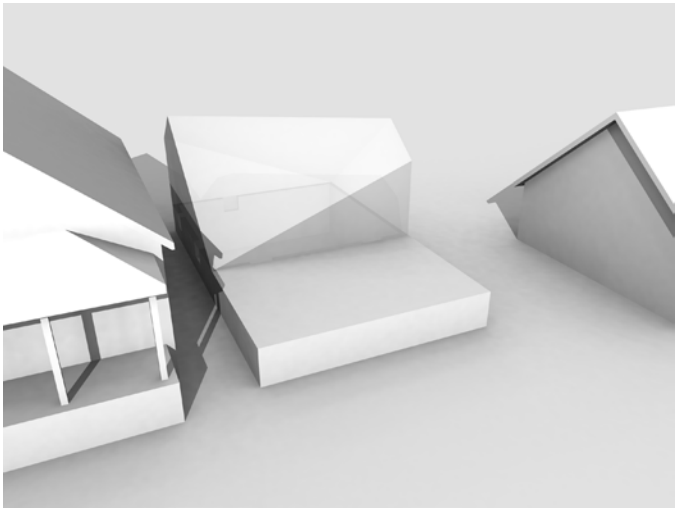
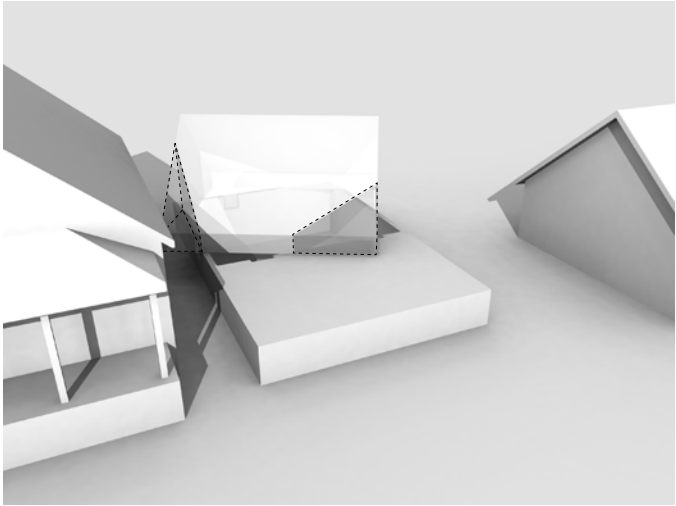

7.

The allowable planting area is determined by sun angles and street orientation.

8.

This porch* can be customized with plants of various heights within the planting area.

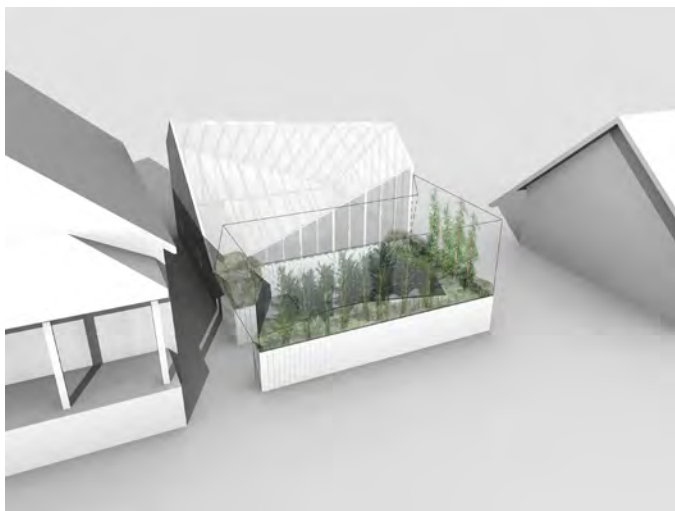
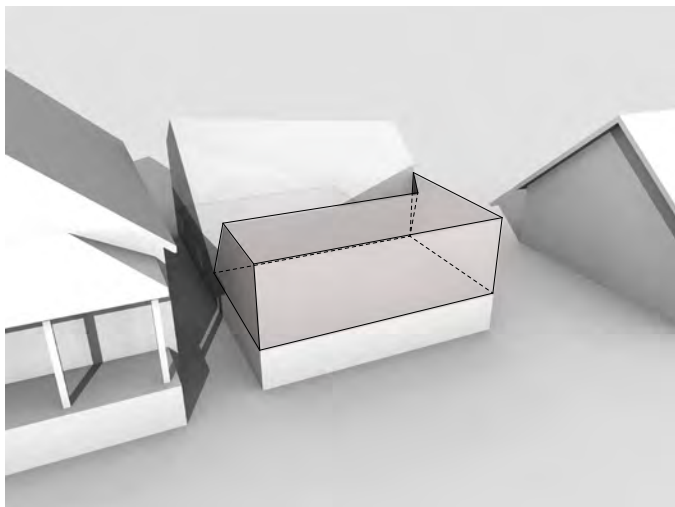

*The Porch

In many bungalow-style houses the porch personalizes the house and makes it a home. The porch is where the space of the street approaches the house, but it is also the architectural device that mediates entry into the home.

The foundation is set back from the porch so the Afterhouse planter porch will be built to maintain the original scale of the house. Additionally, it provides a threshold between the public street and the more private space of the sunken garden.

Just as is the case with the bungalows in the neighborhood, the Afterhouse porch will be customized by its owner without affecting performance. Within a certain volume (shown in red at right), seasonal crops can be grown without affecting the plants inside.

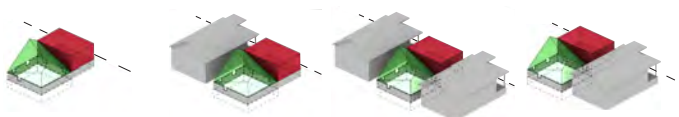

North-Facing Street

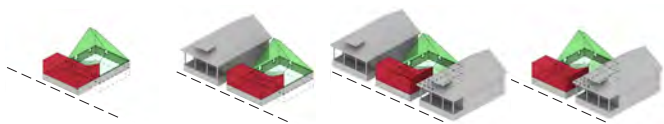

South-Facing Street

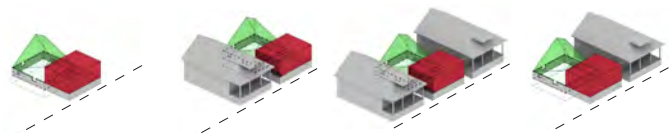

East-Facing Street

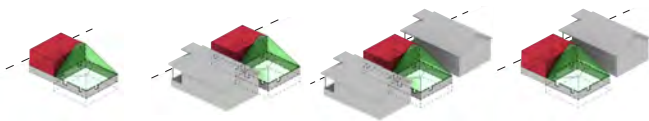

West-Facing Street





2980





© 2018 Zillow

12418

Construction

The construction process of an Afterhouse is a delicate interplay of destruction and creation, demolition and assembly. This sequence must be carefully executed to ensure that the future tenants (plants) will be warm and well-protected.

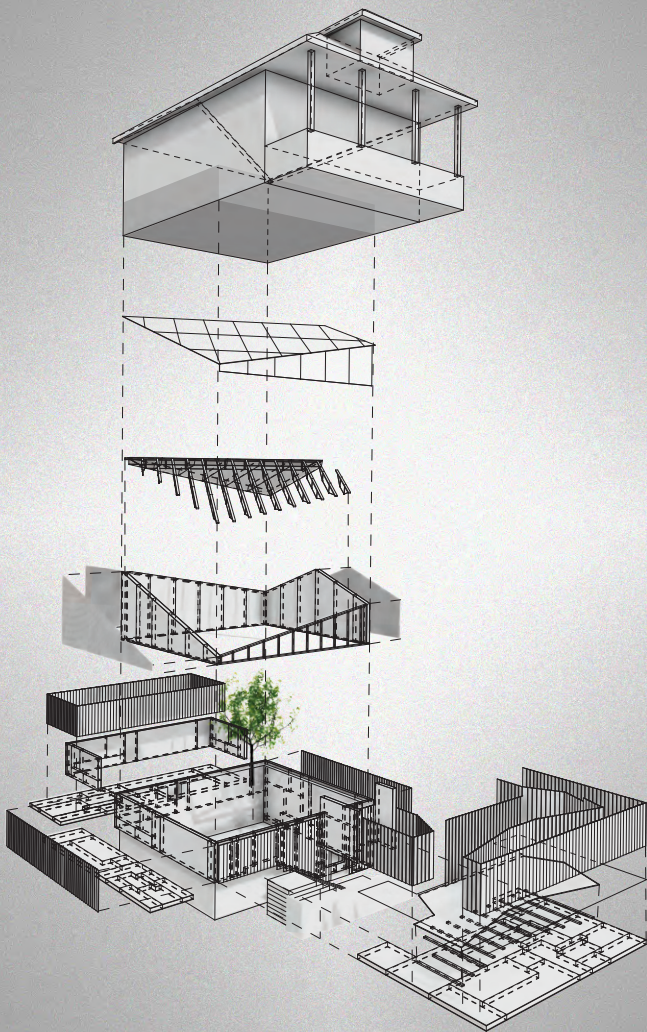

1.

Carefully remove house, leaving foundation intact.

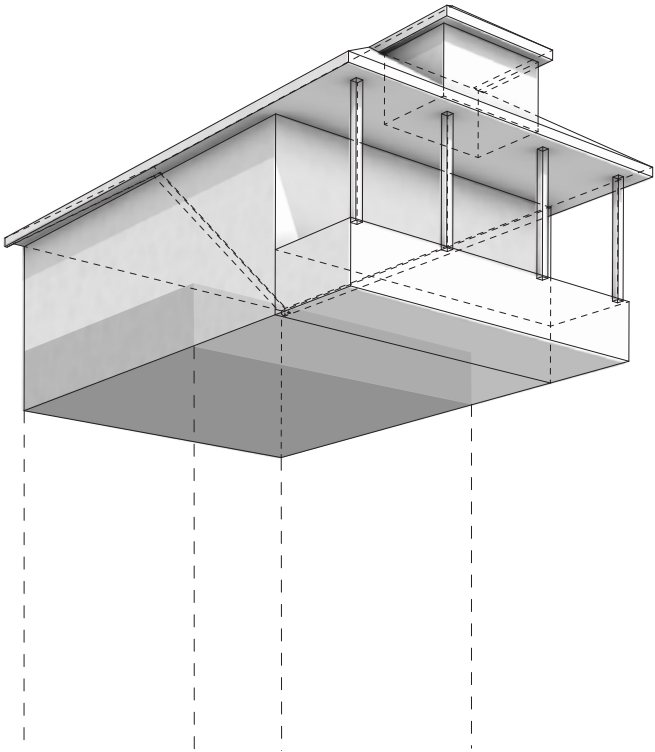

2.

Excavate the stairwell and cut door on South foundation wall.

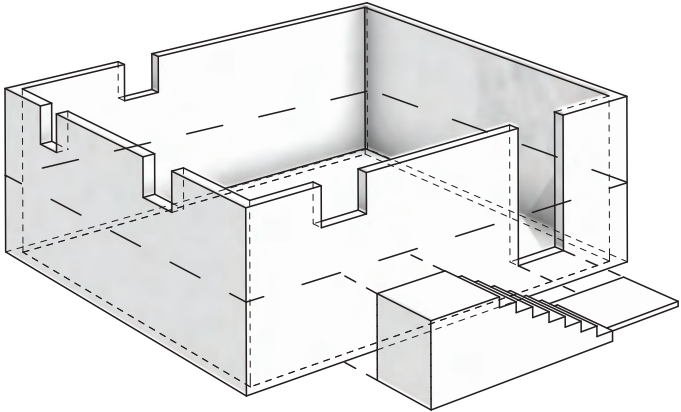

3.

Frame walls and place SIPs.

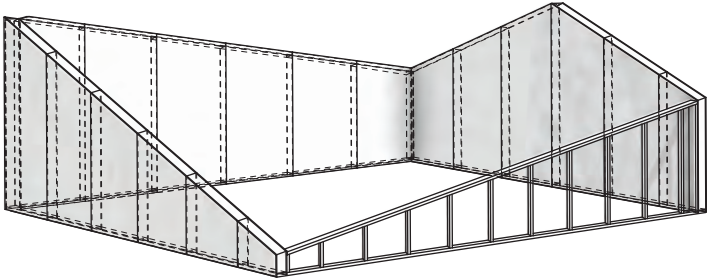

4.

Frame roof and place SIPs.

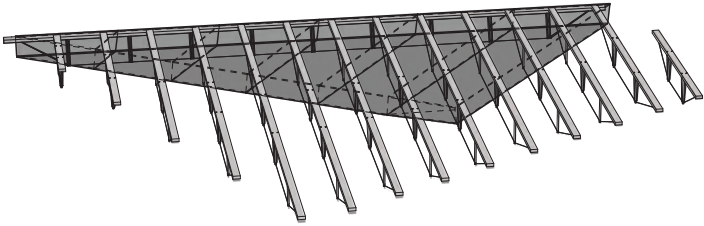

5.

Sheath roof with polycarbonate.

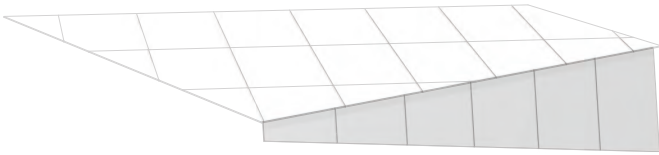

6.

Insulate walls and ground.

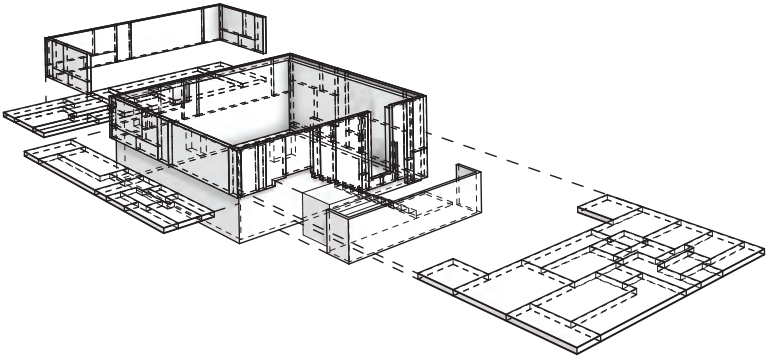

7.

Apply wood and corrugated metal siding.

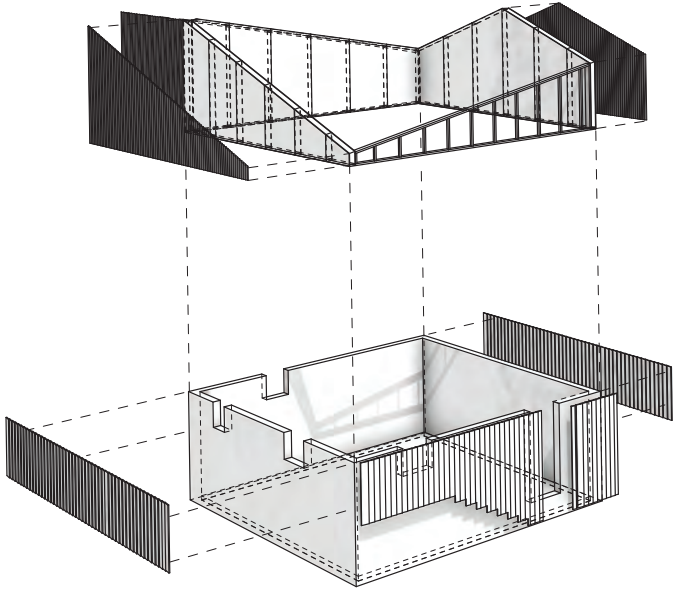

8.

Customize with individual planted porch area.

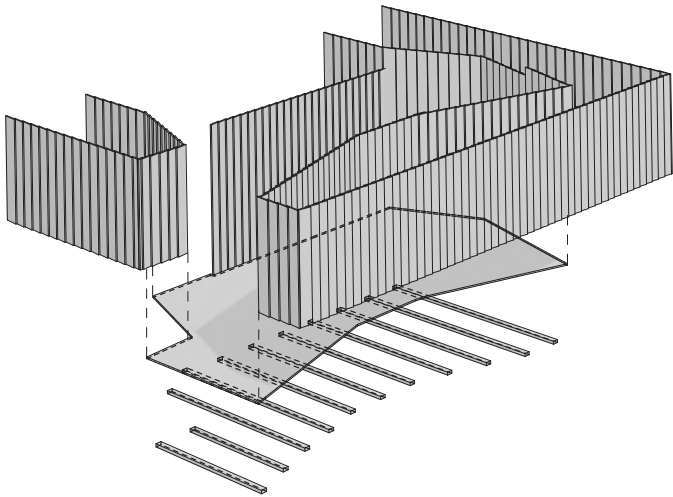



Ingredients

The components of an Afterhouse are carefully chosen, on the basis of economy, embodied energy, durability, and deliciousness.



SIP Scraps

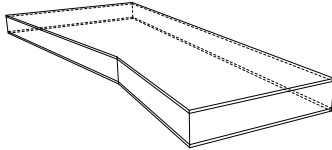

International building materials supplier Insulspan, has generously agreed to donate Structural Insulated Panels (SIPs) cut offs from other projects to Afterhouse.

R-Value @ 6-1/2" = 25

R-Value @ 12" = 48



Polycarbonate

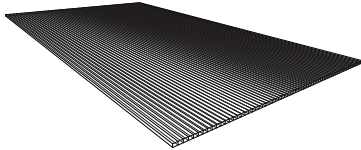

Double-walled polycarbonate is an industry standard material for high-performance greenhouses, due to its insulative qualities and high light-transmissivity.

R-Value @t 8mm double-wall = 1.6



Wood Off-Cuts

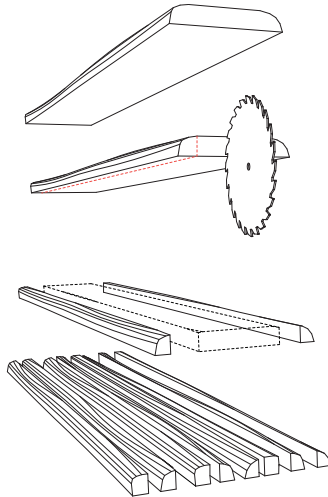

Hardwoods of Michigan sawmill is collecting and donating the irregular slats created through industry standard practice of trimming down irregular 4-Quarter rough planks to square off their edges. These slats are will be used as as inexpensive rainscreen material.



Corrugated Steel

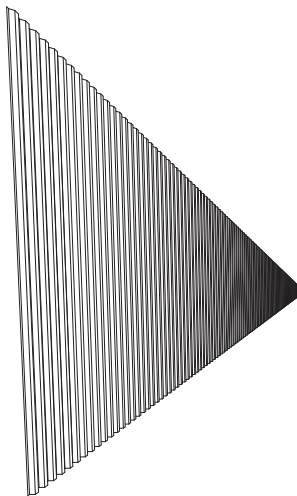

Salvaged corrugated metal roof material can be found at scrap yards around the Detroit Metro area for minimal expense.



DIY Truss

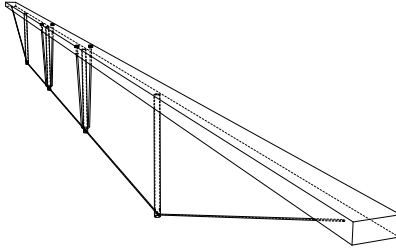

High performance and low cost, made using standard 2x4s, steel strapping, pipe, and cable, the DIY Truss enables the Afterhouse to withstand relatively high loads while allowing for maximum light transmission.

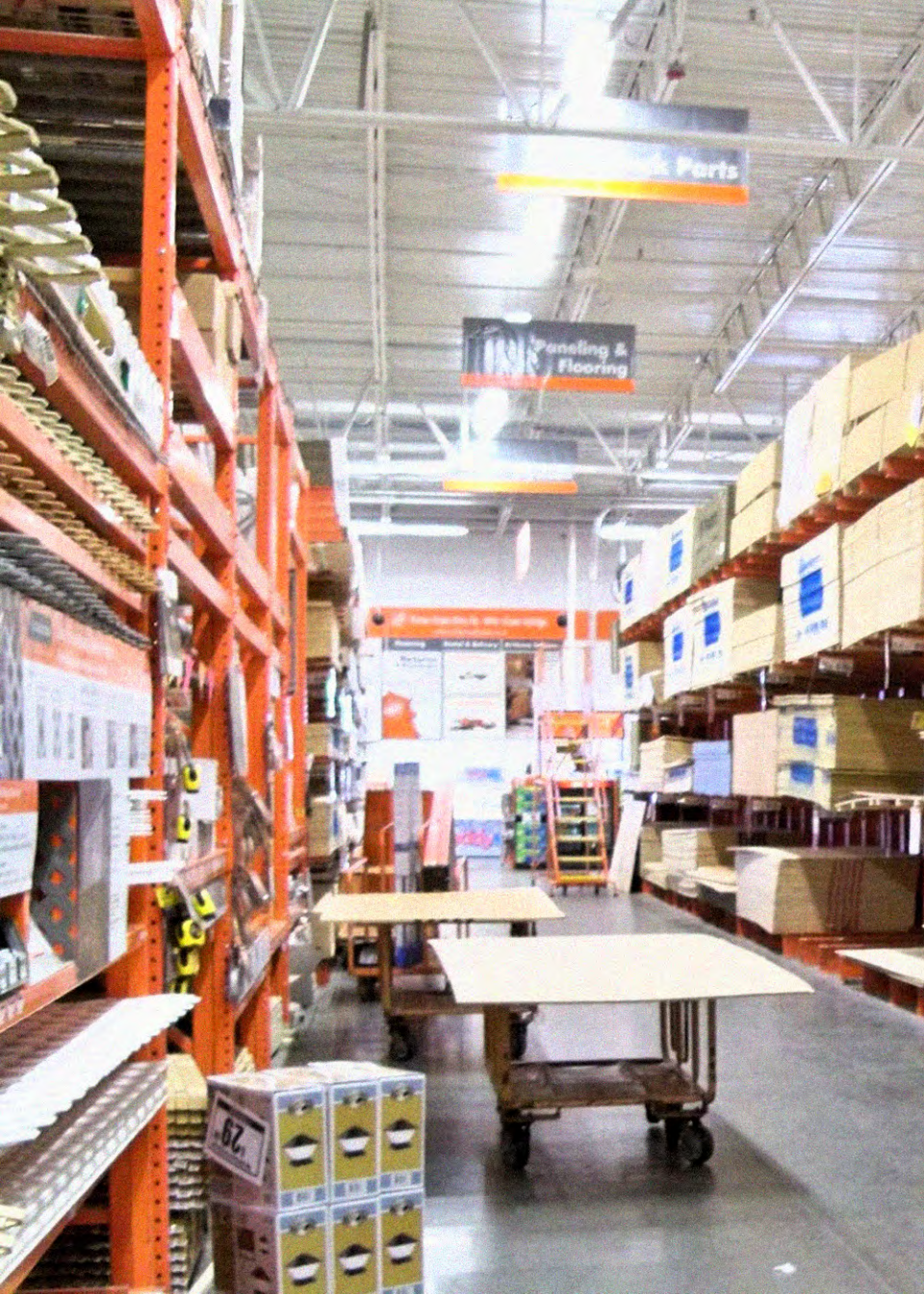

Paints & Parts

Paneling & Flooring

Paints & Parts

29

Kiwi



Kiwifruit, *Actinidia deliciosa*. The berry of a woody vine native to Southern China, the kiwi was known as the Chinese Gooseberry when it was first planted in New Zealand in the early 20th century. Its popularity among American servicemen during World War II inspired the New Zealand Fruit Federation to export it to the United States Market and rename it after New Zealand's brown and fuzzy national bird.

Exposure: Full/Part Sun

Spacing: 10 ft

Water Use: water regularly

Cold Hardiness: Zone 7

Soil preference: Well drained, acidic

Flower Season: Early spring

Harvest Season: Late fall

Self Fertile



Olive



Olive, *Olea europaea arbequina*. Cultivated for thousands and thousands of years, this small broadleaf evergreen tree is native to the Mediterranean, Iraq and Iran and cultivated all over the world for food and fuel.

Exposure: Full Sun

Spacing: 6 ft

Water Use: drought tolerant

Cold Hardiness: Zone 8

Soil preference: Poor soil

Flower Season: Early spring

Harvest Season: Late fall

Self Fertile



Ginger



Ginger, *Zingiber officinale*. The rhizome of a perennial plant, ginger is native South Asia and has been used medicinally and as a spice for thousands of years.

Exposure: Part Sun

Spacing: 12 inches

Water Use: do not allow to dry out

Cold Hardiness: Zone 9

Soil preference: moist, drained, loamy

Flower Season: N/A

Harvest Season: After the first year



Pomegranate



Pomegranate, *Punica granatum*. Cultivated since ancient times and rich in nutrients and phytochemicals, pomegranates have been used medicinally for thousands of years.

Exposure: Full Sun

Spacing: 6 ft

Water Use: drought tolerant

Cold Hardiness: Zone 8

Soil preference: Poor soil,

Flower Season: Early spring

Harvest Season: Late fall

Self Fertile



Yuzu Citrus



Yuzu Citrus, *Citrus ichangensis*. A naturally occurring hybrid long cultivated in East Asia and widely used in Japanese and Chinese cuisine.

Exposure: Full Sun

Spacing: 4 ft

Water Use: drought-tolerant

Cold Hardiness: Zone 8

Soil preference: Poor soil,

Flower Season: Late spring

Harvest Season: Early winter

Self Fertile



Pistachio



Pistachio, *Pistacia vera*. Small, long lived, deciduous tree native to Central Asia and cultivated since ancient times.

Exposure: Full Sun

Spacing: 6 ft

Water Use: drought tolerant

Cold Hardiness: Zone 7

Soil preference: adaptable

Flower Season: Mid spring

Harvest Season: Late summer

Self Fertile



Fig



Fig, *Ficus carica*. Small tree native to the Middle East and western Asia that is one of the first crops ever cultivated.

Exposure: Full Sun

Spacing: 5 ft

Water Use: drought tolerant

Cold Hardiness: Zone 7

Soil preference: well drained, loamy

Flower Season: Early Spring, Summer

Harvest Season: Spring, Late Summer

Self Fertile



Mango



Mango, *Mangifera indica*. The national fruit of India, Pakistan and the Philippines and the national tree of Bangladesh, mangoes have been cultivated for thousand of years.

Exposure: Full Sun

Spacing: 8

Water Use: water regularly

Cold Hardiness: Zone 8

Soil preference: well drained, loamy

Flower Season: Late winter

Harvest Season: Spring

Self Fertile



Pineapple



Pineapple, *Ananas comosus*. Tropical perennial native to South America and spread throughout the Caribbean and Central America in the Pre-Columbian era.

Exposure: Full Sun

Spacing: 3 ft

Water Use: water regularly

Cold Hardiness: Zone 9

Soil preference: well drained, loamy

Flower Season: After 20 months

Harvest Season: After 6 months

Pollinator required for seed formation



Rosemary



Rosemary, *Rosmarinus officinalis*. A woody, evergreen shrub native to the Mediterranean and Asia believed to ward off evil spirits in some cultures, and a symbol of fidelity in others.

Exposure: Full Sun

Spacing: 18"

Water Use: drought tolerant

Cold Hardiness: Zone 8

Soil preference: well drained

Flower Season: winter

Harvest Season: anytime



Specifications

(removable) step up
threshold
isloo style



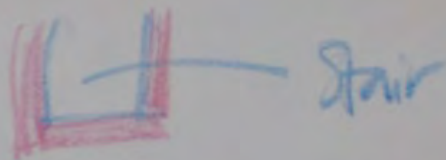

Stair

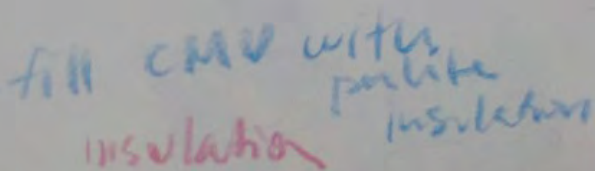

fill CMU with perlite insulation

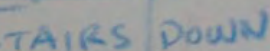

TAIRS DOWN

KATE
ASK ABST ABOUT
Planting Schemes.

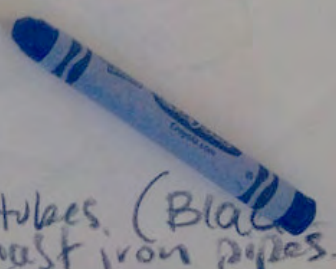

water tubes (Black reused cast iron pipes)

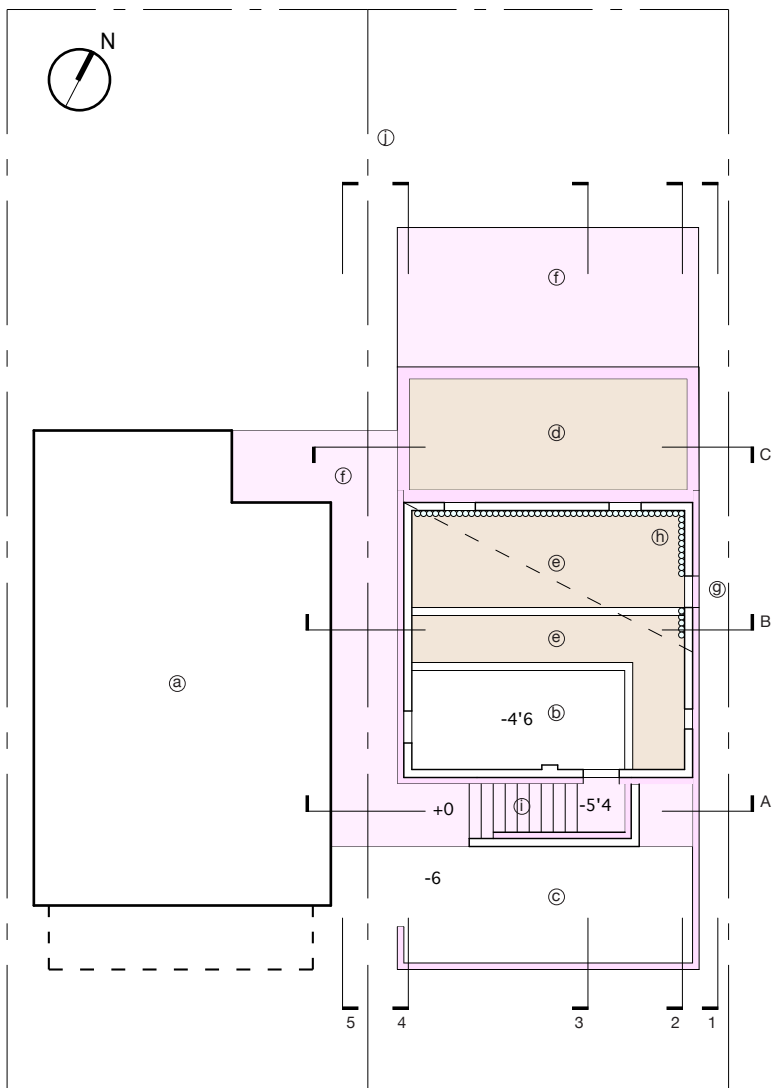

Site/ Floor Plan

- Ⓐ *Farmer's House*
- Ⓑ *Afterhouse*
- Ⓒ *Planter Porch*
- Ⓓ *Outdoor Bed*
- Ⓔ *Planter Bed*
- Ⓕ *Insulated Ground Cover*
- Ⓖ *Access For Soil*
- Ⓗ *Thermal Mass Water Tubes*
- Ⓘ *Stair Down to Afterhouse*
- ⓫ *Former Property Line*
- ⓬ *Ridge*

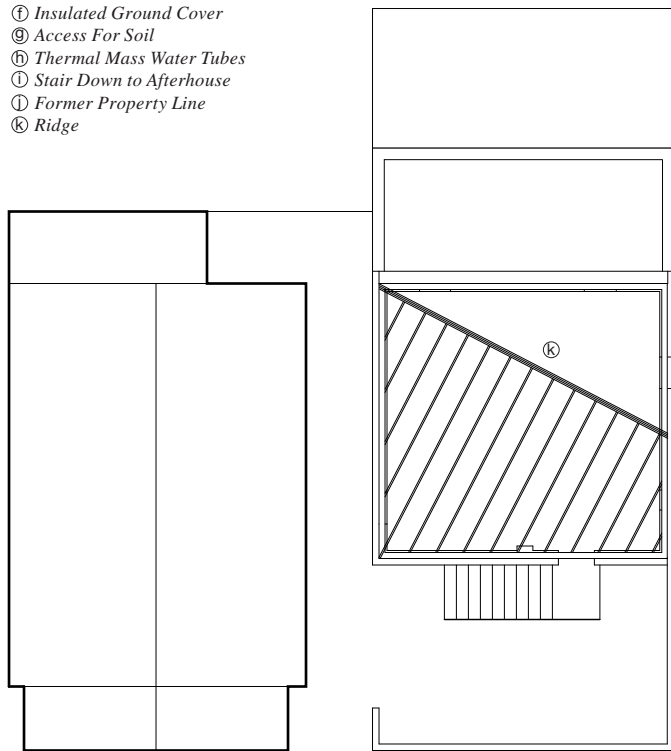

Roof/Framing Plan

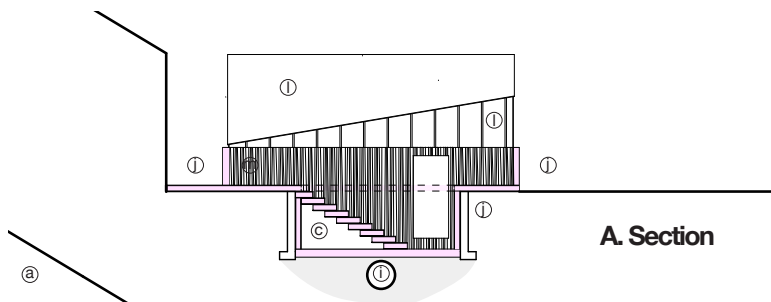

A. Section

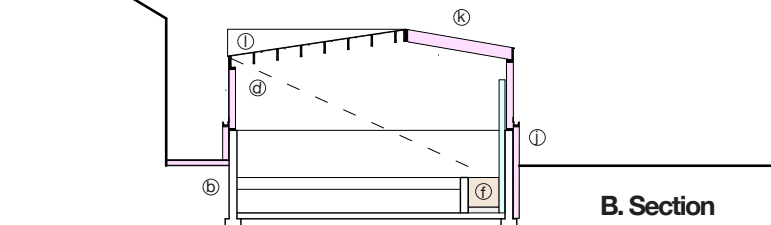

B. Section

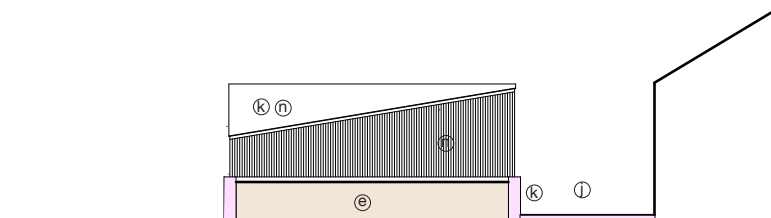

C. Section

- | | |
|-----------------------------|------------------------|
| Ⓐ Farmer's House | Ⓛ Polycarbonate |
| Ⓑ Existing Foundation | Ⓜ Hardwood Scrap Slats |
| Ⓒ New Stairwell | Ⓝ Corrugated Metal |
| Ⓓ Equinox Sun Angle | |
| Ⓔ Out Door Bed Thermal Mass | |
| Ⓕ Tree Planter Bed | |
| Ⓖ Shrub Planter Bed | |
| Ⓝ Thermal Mass Water Tubes | |
| Ⓛ Dry Well with Gravel | |
| Ⓜ 6" SIP Scrap | |
| Ⓝ 12" SIP Scrap | |

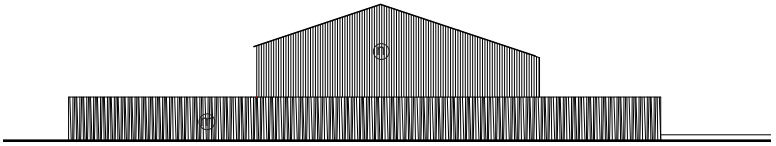

1. Elevation

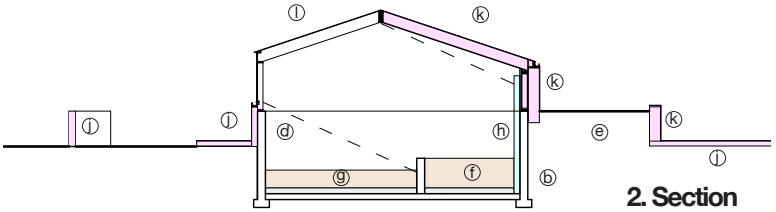

2. Section

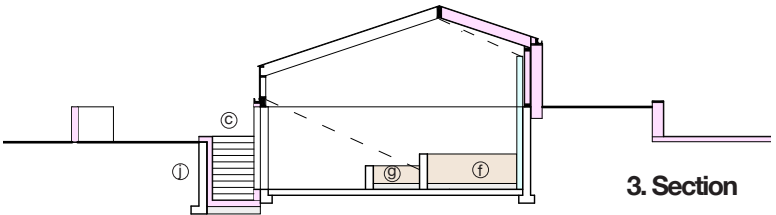

3. Section

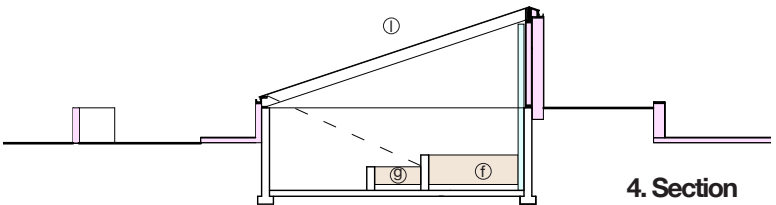

4. Section

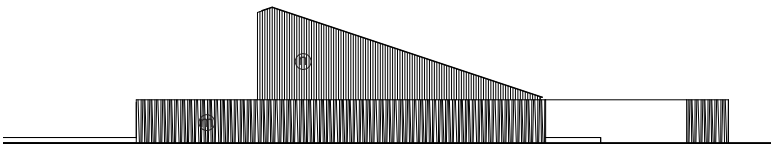

5. Elevation

Project Credits

Project Direction:

""Abigail Murray, Project Principal, Visual Artist

'Ugxgp'O cpmqwej g.'Cuulekvg'Rt qhguaqt'qh'Ctej kgewtg

.....'Wplxgtukl'qh'O lej ki cp"

Jono Sturt, Lecturer of Architecture, University of Michigan

Matthew Schulte, Designer, ARCHOLAB

Student Team

Travis Williams, Student Leader, Undergraduate Student of
Architecture, University of Michigan

Edward Sach, Undergraduate Student of Architecture,
University of Michigan

Community Team

Andrew Malone, owner and artist

Kate Daughdrill, farmer and artist, Burnside Farms

Jamin Townsley, filmmaker

Funding

United States Economic Development Administration Center for
Regional Economic Innovation

Michigan State University Center for Community and
Economic Development

The University of Michigan Undergraduate Research
Opportunity Program (UROP)

The University of Michigan Taubman College for
Architecture and Urban Planning

Industry Sponsors

Insulspan Inc.

Hardwoods of Michigan Inc.